

Brushless DC Motor Driver Module in a Power Flatpack 100-250V, 40 Amp

FEATURES:

- Fully integrated 3-Phase Brushless DC Motor Control Subsystem includes power stage, non-isolated driver stage, and controller stage
- MOSFET Output Stage
- 40A Average Phase Current with 10V to 150V Maximum Bus Voltage
- Internal Precision Current Sense Resistor (10W max. dissipation)
- Cycle by cycle current limiting.
- Fixed frequency PWM from zero speed to full speed.
- Closed-loop Speed Control of Motor
- Direction Input for direction reversal of Motor
- Tacho output with average output proportional to speed
- Brake Input for Dynamic Braking of Motor
- Overvoltage/Coast Input for Shutdown of All Power Switches
- Enable/Disable input with Soft Start for Safe Motor Starting
- Hermetic or non-hermetic device (3.10" x 2.10" x 0.385")
- **Hermetic Device Part # (SMC6M40-XX)**
- **Non-Hermetic Device Part # (SMC6M40-XX-1)**

APPLICATIONS:

- Fans and Pumps
- Hoists
- Actuator Systems

DESCRIPTION:

The SMC6M40-XX is an, integrated three-phase brushless DC motor controller/driver subsystems housed in a 43 pin power flatpack. The SMC6M40-XX is best used as a two quadrant speed controller for controlling/driving fans, pumps, and motors in applications which require small size. Many integral control features provide the user much flexibility in adapting the SMC6M40-XX to specific system requirements. The small size of the complete subsystem is ideal for aerospace, military, high-end industrial, and medical applications.

TECHNICAL DATA
DATA SHEET 1023, REV. E

COMMUTATION TRUTH TABLE

This table shows the Phase Output state versus the state of the Hall-Effect and Direction Inputs. The commutation coding shown reflects Hall-Effect sensors that are spaced at 120° mechanical increments. Also, internal protection logic disables all three Phase Outputs when the Hall-Effect Inputs are set to an illegal condition (i.e., all logic low or all logic high).

DIGITAL INPUTS				PHASE OUTPUTS		
Dir	H1	H2	H3	A	B	C
1	0	0	1	Hi-Z	Sink	Source
1	0	1	1	Sink	Hi-Z	Source
1	0	1	0	Sink	Source	Hi-Z
1	1	1	0	Hi-Z	Source	Sink
1	1	0	0	Source	Hi-Z	Sink
1	1	0	1	Source	Sink	Hi-Z
0	1	0	1	Sink	Source	Hi-Z
0	1	0	0	Sink	Hi-Z	Source
0	1	1	0	Hi-Z	Sink	Source
0	0	1	0	Source	Sink	Hi-Z
0	0	1	1	Source	Hi-Z	Sink
0	0	0	1	Hi-Z	Source	Sink
X	0	0	0	Hi-Z	Hi-Z	Hi-Z
X	1	1	1	Hi-Z	Hi-Z	Hi-Z

Part Number	Motor Supply Voltage	Motor Peak Voltage	Average Output Current	Peak Output Current	Rds(on) ID =20A	Hermetic?
SMC6M40-10-YY	60	100	40	60	15	Yes
SMC6M40-10-1-YY	60	100	40	60	15	No
SMC6M40-25-YY	150	250	40	60	60	Yes
SMC6M40-25-1-YY	150	250	40	60	60	No

PART NUMBER/SELECTOR GUIDE TABLE

Current Sense Resistor value and lead bend options shall be:

SMC6M40-XX-1-YYZ where **YY is the sense resistor value** and **Z is the lead bend option** if needed

Part number SMC6M40-XX-1-10B has a 10mOhm resistor, and option B lead bend.

For an open frame without a cover add -O to the part number.

TECHNICAL DATA
DATA SHEET 1023, REV. E

ABSOLUTE MAXIMUM RATINGS

Characteristic	Maximum
Motor Supply Voltage SMC6M40-10 SMC6M40-25	80 V 200
Motor Peak Voltage SMC6M40-10 SMC6M40-25	100 V 250V
Average Output Current	40 A
Peak Output Current	60 A
Control Supply Voltage VCC	18 V
Logic Input Voltage (Note 1)	-0.3 V to +8 V
Reference Source Current	-30 mA
Logic Input Voltage	-0.3 to +8 V
Error Amplifier Input (EA1+/EA1-)	-0.3 to +10 V
Error Amplifier Output Current	±8 mA
Spare Amplifier Input Voltage (EA2+/EA2-)	-0.3 to +10 V
Spare Amplifier Output Current	±8 mAdc
Current Sense Amplifier Input Voltage (ISH/ISL)	-0.3 V to +6 V
Current Sense Amplifier Output Current	±10 mAdc
Tachometer Output Current	+/- 10 mA
PWM Input Voltage	- 0.3 V to +6 V
Operating & Storage Junction Temperature	-55 °C to +150 °C
Power Devices Thermal Resistance R_{thjC}	1.0 °C/W
Pin-to-Case Voltage Isolation, at room conditions	600V DC
Lead Soldering Temperature, 10 seconds maximum, 0.125" from case * Tcase = 25° C	300°C

Recommended Operating Conditions (T_C=25 °C)

Characteristic	Maximum
Motor Supply Voltage SMC6M40-10 SMC6M40-25	60 V 150 V
Average Output Current for SMC6M40-XX, T _C =80°C	30 A
Control Supply Voltage VCC	15 V +/-10%

Note 1: Logic Inputs: Direction, Hall Inputs (H1...H3) Over-voltage - Coast, Speed, and Quad Select.
 Note 2: The internal current sense resistor is limited to 6 Watt dc power dissipation. Other values are available.
 Please contact the factory for more information.

TECHNICAL DATA
DATA SHEET 1023, REV. E

PARAMETER SYMBOL CONDITIONS (NOTE 1)	MIN.	TYP.	MAX.	UNITS
Power Output Section				
Drain-Source Leakage Current I_{DSS} at 0.8V _{DSS}			250	μA
Diode Forward Voltage V_F at $I_F = 20$ A			1.0	V
Diode Reverse Recovery Time t_{rr} $I_F = 20$ A, $di/dt = -100$ A/usec,			300	nSec
Drain-to-Source On-Resistance $R_{DS(on)}$ $I_D = 20$ A 100V, 40A Device, SMC6M40-10 250V, 40A Device, SMC6M40-25			15 60	mΩ
$V_{CC} = 12$ V Note (3)				
Control Section				
Control Supply Current I_{CC} at $V_{CC} = 12$ V			30	mA
Control Turn-On Threshold $V_{CC(+)}$ T_c over operating range	9.0	10.5	11.0	V
Driver Turn-On Threshold $V_{CC(+)}$ T_c over operating range	8.0	9.0	10.0	V
5V Reference Section				
Output Voltage V_{ref}	4.7	5.0	5.3	V
Output Current I_o	-	-	30	mA
Load Regulation $I_{load} = 0$ mA to -20 mA	-	-	30	mV
Error Amplifier / Spare Amplifier Sections				
EA1 / EA2 Input Offset Current I_{os} $V(\text{pin } 2) = V(\text{pin } 4) = 0$ V $V(\text{pin } 3) = V(\text{pin } 6) = 0$ V	-	6	75	nA
EA1 / EA2 Input Bias Current I_{in} $V(\text{pin } 2) = V(\text{pin } 4) = 0$ V $V(\text{pin } 3) = V(\text{pin } 6) = 0$ V	-	100	500	nA
Input Offset Voltage, $V_{CM} = 0$ V	-	1.5	5	mV
Amplifier Input Common-mode Voltage Range $V_{CC} = 12$ V	0	-	9	V
Amplifier Output Voltage Range V_{OH}	10	11	-	V
Amplifier Output Voltage Range V_{OL}	-	0.1	0.5	V
PWM Comparator Section				
Propagation Delay Time	70	-	150	nsec
Input Common Mode range	2.0		8.0	V
Current-Sense Amplifier Section				
ISH / ISL Input Voltage Range	-0.5	-	$V_{CC} - 1.0$	V
Input Offset Voltage	-	-	8	mV
Input Bias Current	5	10	15	μA
Amplifier Voltage Gain	4.75	5.0	5.25	V
High Level Output Voltage, $I_{out} = -100$ μA	6.0	-	-	V
Low Level Output Voltage, $I_{out} = 100$ μA	-	-	70	mV
Output Source Current	300	-	-	μA
Over-Current Comparator				
Input Common-mode Range	0.0	-	50	V
Propagation Delay Time	40	170	260	nsec
Logic Input Section				
H1, H2, H3 High-Level Input Voltage Threshold	1.7	1.9	2.1	V
H1, H2, H3 Input Hysteresis	0.6	-	1.0	V
H1, H2, H3 Input Current, $0.0 < V_{in} < 5.0$ V	-	-30	-	μA
Coast, Start/Stop High-Level Input Voltage Threshold	3.6	-	-	V
Coast, Start/Stop Low-Level Input Voltage Threshold	-	-	1.9	V
Quad, Brake, Dir in High-Level Input Voltage Threshold	3.6	-	-	V
Quad, Brake, Dir in Low-Level Input Voltage Threshold	-	-	1.9	V
Tachometer				
Tachometer Output High Level V_{oh}	4.7	5.0	5.3	V
Tachometer Output Low Level V_{ol}	-	-	50	mV
Tachometer On-Time t_{on}	130	140	150	us
Tachometer On-Time Variation				
Speed Input Threshold Voltage V_{th}	0.200	0.250	0.280	V
Oscillator Section				
Oscillator Frequency f_o	16	18	20	kHz
Over-Temperature Shutdown				
Trip Temperature	135	145	155	°C
Reset Temperature	115	125	135	°C

TECHNICAL DATA
DATA SHEET 1023, REV. E

SPECIFICATION NOTES:

- 1- All parameters specified for Ta = 25 °C, Vcc = 15Vdc, and all Phase Outputs unloaded. All negative currents shown are sourced by (flow from) the pin under test
- 2- Either ISH or ISL may be driven over the range shown.
- 3- Pulse Test: Pulse Width < 300 µSec, Duty Cycle < 2%.

PINOUTS

PIN#	NAME	PIN#	NAME
1	VCC	23	Speed Input
2	EA1 “-” Input	24	Direction Input
3	EA2 “+” Input	25	CSH
4	EA1 “+” Input	26	CSL
5	+5V Reference Output	27	+VDC Return
6	EA2 “-” Input	28	+VDC Return
7	EA2 Output	29	Source C
8	EA1 Output	30	Source C
9	loc Ref	31	Phase C Output
10	Direction Out	32	Phase C Output
11	Iso	33	+VDC
12	ISH	34	Source B
13	ISL	35	Source B
14	Quad Select Input	36	Phase B Output
15	Tachometer Output	37	Phase B Output
16	Brake Input	38	+VDC
17	Over-voltage/Coast Input	39	Source A
18	Start/Stop Input	40	Source A
19	Ground	41	Phase A Output
20	HC Input	42	Phase A Output
21	HB Input	43	+VDC
22	HA Input	(Case)	(No Connection)

TECHNICAL DATA
DATA SHEET 1023, REV. E

MECHANICAL OUTLINE

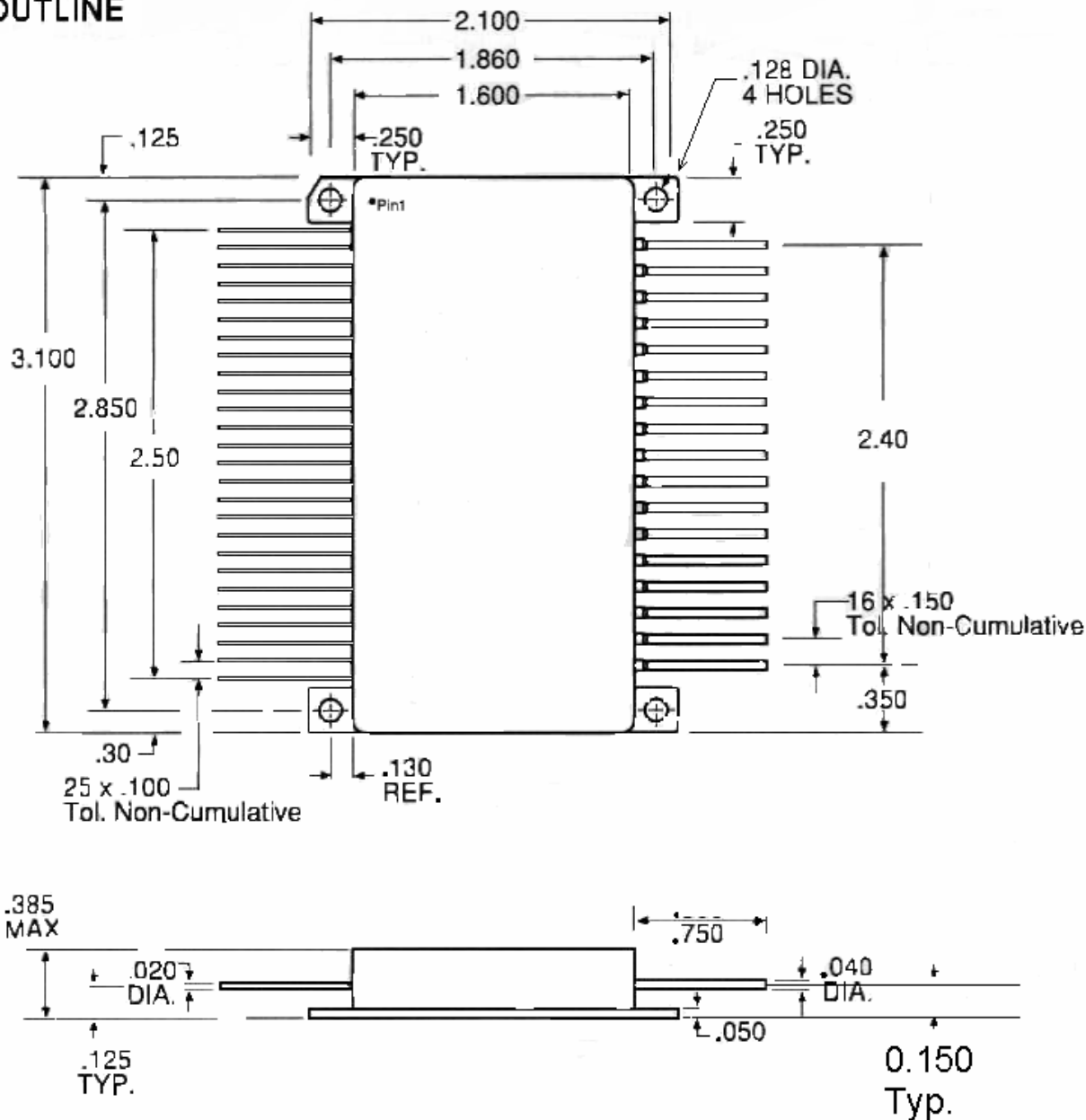
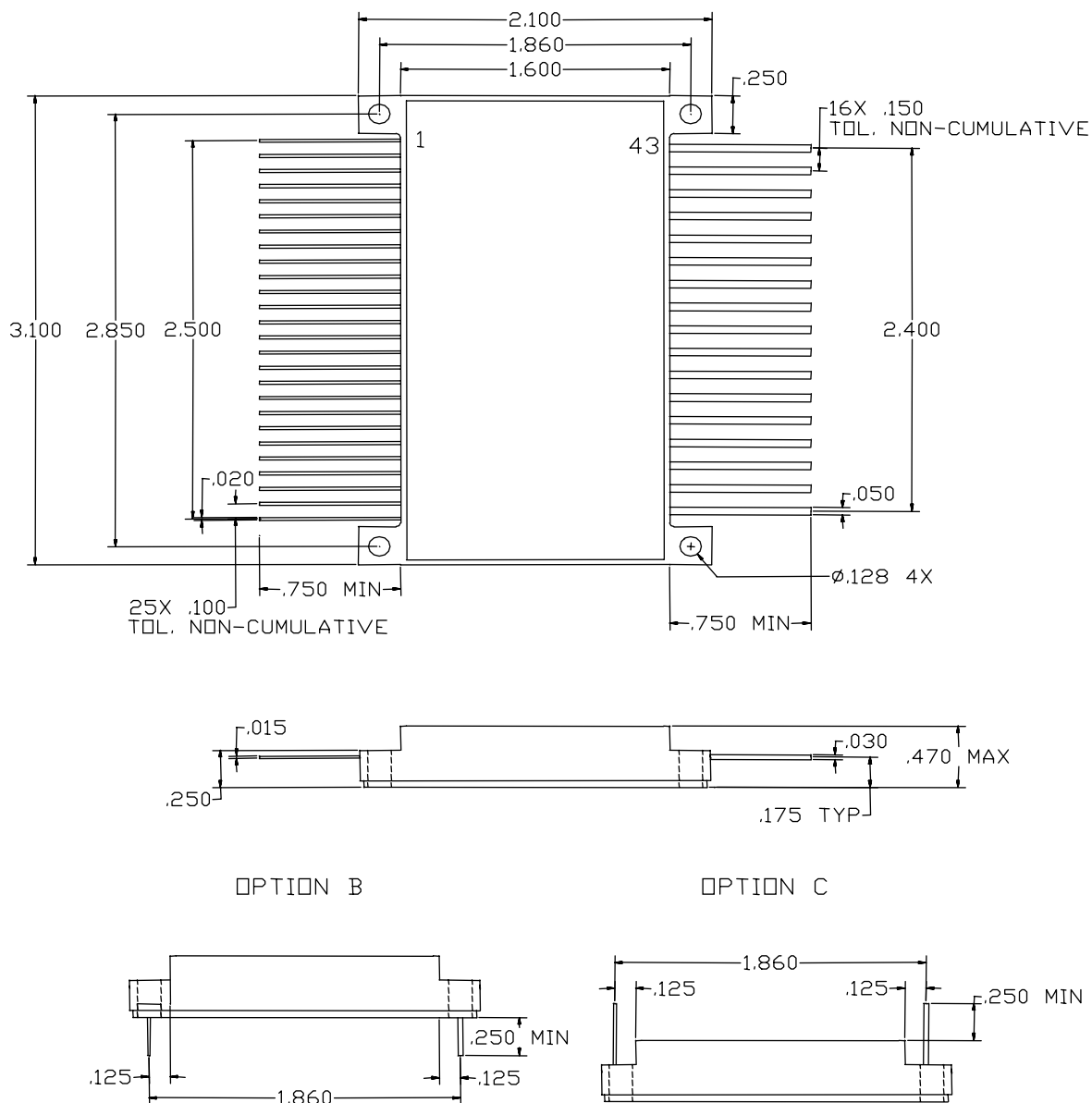

Fig. 2: Mechanical Outline For Hermetic Package, FLPK1, SMC6M40-XX

TECHNICAL DATA
DATA SHEET 1023, REV. E

**Fig. 3: Mechanical Outline For Plastic Case Package, FLPK1-1
SMC6M40-XX-1**



For Option B part number is SMC6M40-XX-1-YYB, for Option C part number is SMC6M40-XX-1-YYC,
Where YY is the Current Sense Resistor Value in m Ohms 05,10,30,.....

Pin Descriptions

Vcc (Pin 1), is the input biasing supply connection for the controller. Under-voltage lockout keeps all outputs off for Vcc below 10.5V. Vcc pin should be connected to an isolated 15V power supply. The return of Vcc is pin 19.

EA1- (Pin 2), is the error amplifier inverting input.

EA2+ (Pin 3), is the non-inverting input of a spare amplifier.

EA1+ (Pin 4), is the error amplifier non-inverting input. EA1- and EA1+ are not internally committed to allow for a wide variety of uses. They can be connected to Io for current-mode control, or Tach output for voltage-mode control.

+5V Ref(Pin 5), is a 5V reference with 30mA of maximum available output current. This pin should be bypassed to Gnd with 1-5 μ F capacitor depending on the load current.

EA2- (Pin 6), is the inverting input of a spare amplifier.

EA2 (Pin 7), out is the output of a spare amplifier.

EA1 (Pin 8), out is the output of the error amplifier and is internally connected to the PWM comparator.

loc-Ref (Pin 9), is the over-current reference voltage. It is internally set to 1.15V. This reference can be reduced by connecting a resistor between loc Ref and Gnd . The resistor value is

$$R = (\text{loc-Ref}) / (0.05 - 0.043 * (\text{loc-Ref})) \text{ K}\Omega \quad (1)$$

Also, loc Ref can be increased by connecting a resistor between loc Ref and the 5V reference. The resistor value is

$$R = (5.0 - (\text{loc-Ref})) / (0.043 * (\text{loc-Ref}) - 0.05) \text{ K}\Omega \quad (2)$$

This pin is connected to the over-current comparator for cycle-by-cycle current limiting. The over-current reference voltage is set according to the formula

$$\text{loc-Ref} = R_s * I_p * 5 \text{ volts} \quad (3)$$

Where R_s is the current sense resistor value in ohms and I_p is peak current limit in amperes.

Dir out (Pin 10), is direction output representing the actual direction of the rotor as decoded from the hall sensors. There are two valid transitions of the hall sensor inputs; one translates to a clockwise rotation and another which translates to a counterclockwise rotation. The polarity of Dir-out is the same as Dir-in while motoring.

TECHNICAL DATA
DATA SHEET 1023, REV. E

Is-out (Pin 11), is the absolute value output of the current sense amplifier.

$$Is-out = ABS(ISL - ISH) \quad (4)$$

ISH (Pin 12), is the non-inverting input of the current sense amplifier.

ISL (Pin 13), is the inverting input of the current sense amplifier.

Quad (Pin 14), is the select input of two-quadrant (Quad=0) or four-quadrant (Quad=1) operation.

Tach-out (Pin 15), is a fixed pulse width variable frequency output proportional to the motor speed. A pulse is generated at both rising and falling edges of HA, HB, HC inputs. So this output can be used as a true tachometer for speed feedback with an external filter or averaging circuit which usually consists of a resistor and capacitor, as shown in Figs 9 & 10.

Brake (Pin 16), is a digital input which causes the device to enter into brake mode. In brake mode all three low-side switches are turned off and high-side switches are turned on. The only conditions that can inhibit the high-side command during brake mode are UVLO, the output of the PWM comparator, Coast input, or Start/Stop input.

Coast (Pin 17), is a digital input that disables all outputs once pulled high. This input is internally pulled low.

Start/Stop (Pin 18), is a digital input that disables all outputs once pulled low. This input is pulled high internally. This input can be used as enable/disable input using a switch. If the switch is opened, the controller is enabled. If the switch is closed to Gnd, the controller is disabled.

Signal Gnd (Pin 19), is the reference ground for all control signals of the device. All bypass capacitors, loop compensation components must be connected as close as possible pin 19. This pin **should not** be externally connected to the power ground pins 27 and 28.

HC (Pin 20), is hall input of phase C.

HB (Pin 21), is hall input of phase B.

HA (Pin 22), is hall input of phase A.

HA, HB, HC are designed to accept rotor position information from hall sensors positioned 120° apart. Motors with 60° position sensing may be used if one or two of the hall-effect sensor signals is inverted prior to connection to the hall-effect inputs.

HA, HB, HC inputs are internally pulled up, zener clamped to 6.2V, and filtered.

Speed-in (Pin 23), is a speed input to latch the direction input when the motor is spinning fast.

TECHNICAL DATA
DATA SHEET 1023, REV. E

Dir-in (Pin 24), is the direction digital input. Logic "H" correspond to forward rotation, and logic "L" correspond to reversed rotation.

The direction input can be latched by Speed-in input. As long as Speed-in is less than 0.250V, the direction latch is transparent. When Speed-in is higher than 0.250V changing direction of rotation will enable coast until the Speed-in drops below 0.250V. Direction latch is recommended in two-quadrant operation mode to allow the motor to coast to a safe speed before reversing.

CSH (Pin 25), is the positive terminal of the current sense resistor.

CSL (Pin 26), is the negative terminal of the current sense resistor.

The current sense terminals produce a differential voltage equal to the motor current times the sense resistance (5 or 10 m Ω typical). There is an internal 2nF filter capacitor across pins 25 and 26, There is also a 100 Ω resistor between each pin and each end of the current sense resistor. Pins 25 and 26 shall be externally connected to pins 12 and 13 to activate the cycle-by-cycle current limiting.

+VDC Rtn (Pins 27 & 28), are the motor supply return. Pins 27 and 28 **should not** be connected to the signal Gnd pin 19.

Source Terminals (Pin 29, 30, 34, 35, 39, 40), are the source terminals of the three arms of the three-phase bridge. These pins shall be shorted together externally using a low impedance bus to minimize power loss.

Phase C Outputs (Pin 31, 32), are phase C terminals. Both terminals shall be used.

Phase B Outputs (Pin 36, 37), are phase B terminals. Both terminals shall be used.

Phase A Outputs (Pin 41, 42), are phase A terminals. Both terminals shall be used.

+VDC (Pins 33, 38, 43), are the motor input power supply positive terminal. These pins shall be shorted together externally using a low impedance bus. +VDC bus should bypassed to +VDC Rtn with adequately voltage-rated low ESR capacitor, whose value can is least 10-15 μ F per ampere of average motor current.

Application Information

60° Rotor Position Sensing

SMC6M40-XX is designed to operate with 120° position sensing encoding. In this format, the three position sensor signals are never simultaneously high or low. Motors whose sensors provide 60° encoding can be converted to 120° using the circuit shown in Fig. 4.

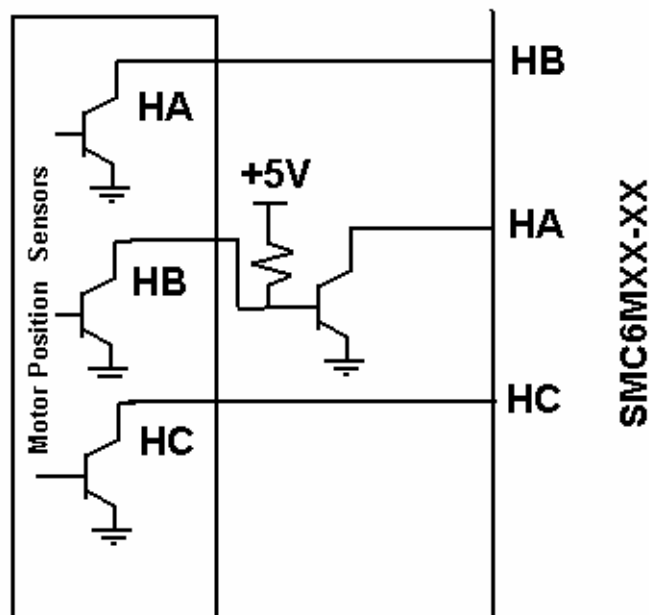

Fig. 4. Converting Hall Sensors Position From 60° to 120°

Two-Quadrant vs Four-Quadrant

In two-quadrant mode only one switch is modulated at any time while in four-quadrant operation two switches are modulated. This results in a more efficient controller and less EMI emission when operating in two-quadrant mode. However, two-quadrant mode has some limitations as explained below.

Fig. 5 illustrates the four possible quadrants of operation for a motor. Two-quadrant mode refers to a motor operating in quadrants I and III. With a two-quadrant BDC motor, friction is the only force to decelerate the load. Four-quadrant control provide controlled operation in all quadrants, including II and IV, where torque and rotation are of opposite directions.

TECHNICAL DATA
DATA SHEET 1023, REV. E

When configured in two-quadrant mode, **Quad=0**, SMC6M40-XX modulates only the high-side devices of the output power stage. The current paths within the output stage during the PWM on and off times are illustrated in Fig. 6. During the on time, both switches S1 and S4 are on, the current flows through both switches and the motor winding. During the off time, the upper switch S1 is shut off, and the motor current circulates through the lower switch S4 and D2. The motor is assumed to be operated in quadrants I or III.

If operation is attempted in quadrants II or IV by changing the Dir input, S1 and S4 are turned off and S2 and S3 are turned on. Under this condition motor current very quickly decays, reverses direction and increases until the over-current limit is reached. At this point, S3 turns off the current circulates in S2 and D4, and continue to rise due to the fact that the back emf is in-phase with the current because the motor direction has not changed yet. Fig. 7 illustrates the current path in this case. Under these conditions there is nothing to limit the current other than the controller and the motor impedance. These circulating currents can result in damage to the power stage if the load inertia is high.

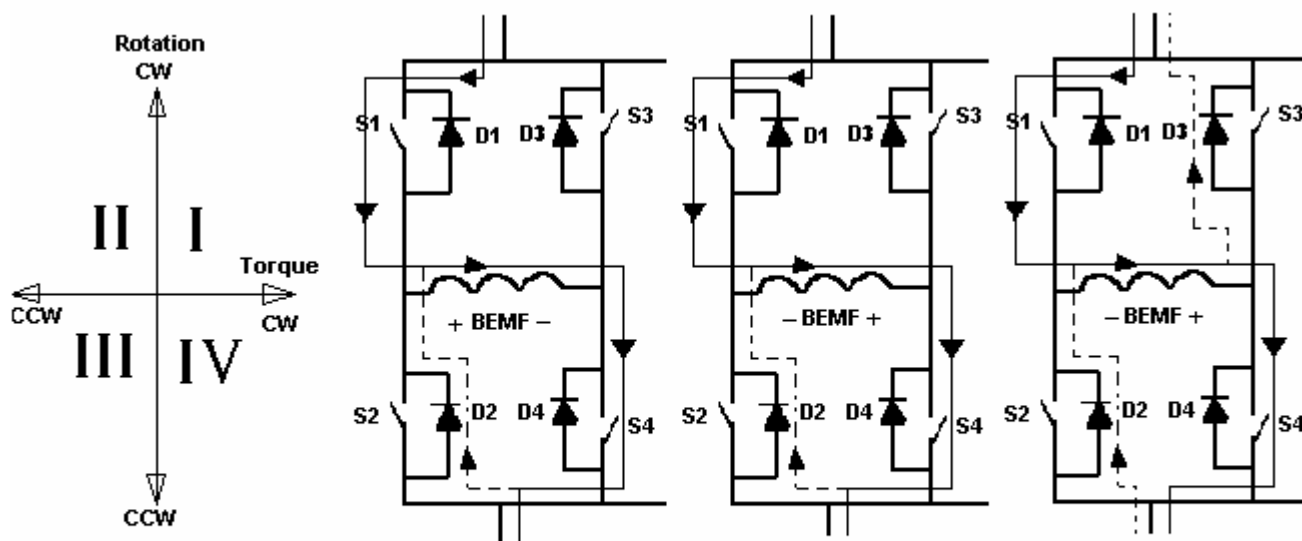

Fig. 5. Four Quadrants of Operation

Fig. 6. Two-Quadrant Forward

Fig. 7. Two-Quadrant Reverse

Fig. 8. Four-Quadrant Reverse

In four-quadrant mode, **Quad=1**, both upper and lower switches are modulated. Motor current always decays during off time, eliminating any uncontrolled circulating current. In addition, the current always flows through the current sense resistor. Fig. 8 illustrates the current paths during torque reversal.

It is recommended in two-quadrant operation to utilize the speed input, pin 23, for safe direction reversal. The direction input can be latched by speed input. As long as Speed-in is less than 0.250V, the direction latch is transparent. When Speed-in is higher than 0.250V changing direction of rotation will enable coast until the Speed-in drops below 0.250V. The Speed-in signal is obtained by low-pass filtering the Tach output, pin 15, using RC filter.

Control Modes

Typically, speed regulation is achieved by regulating the average input voltage to the motor, while torque regulation is achieved by current control. Voltage and current control loops may be combined to achieve a specific speed-torque curve.

Voltage-Mode Control

Fig. 9 shows the implementation of a typical speed control loop. A voltage command proportional to the desired speed is applied at pin4 and can be set by a potentiometer, R3. The speed feedback signal is obtained by low-pass filtering the Tach, pin15, output using R1 and C1. Small signal compensation of the speed control loop is provided by an internal error amplifier. The integrating capacitor C2 places a pole at 0 HZ and a zero in conjunction with R2. This zero can be used to cancel the low-frequency motor pole and to cross the loop with –20dB gain response.

The output of the error amplifier is connected to the PWM comparator. Since the motor speed is proportion to the average phase voltage, the speed is controlled via duty cycle control.

For open loop speed control, pin 2 shall be shorted to pin 8. The error amplifier acts as a voltage follower and buffer to the command input.

Cycle-by-cycle current limiting is provided by connecting pins 25 and 26 to pins 12 and 13. The over-current limit is set by the over-current reference locRef at pin 9. This reference is set internally to 1.15V, and can be altered using a resistor externally, see equations (1) to (4) for details. The current signal is filtered internally, and amplified with a gain of 5.

Current Mode Control

Fig. 10 shows the implementation of a typical torque control loop. A voltage command proportional to the desired current is applied at pin 4 and can be set by a potentiometer, R3. The current feedback signal, Iso at pin11, is obtained by the internal current sensor and the absolute value amplifier. Small signal compensation of the feedback control loop is provided by an internal error amplifier. The error amplifier output is connected to the PWM comparator. Since the torque is proportional to the average phase current, the torque is controlled via duty cycle control.

It is recommended to set the over-current limit reference locRef at pin 9 at a value slightly higher than the maximum peak command current. This will maintain the **cycle-by-cycle** current limiting even if the error amplifier saturates during large signal disturbance.

TECHNICAL DATA
DATA SHEET 1023, REV. E

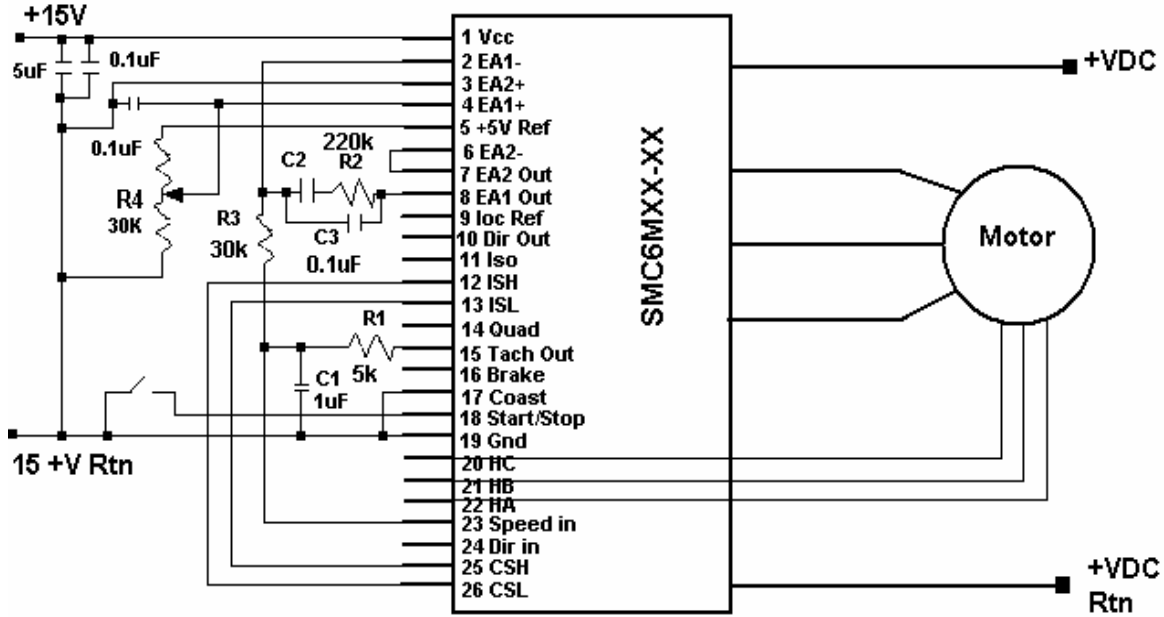

Fig. 9. Closed-Loop Speed Control
(Two-Quadrant Operation with Safe Direction Reversal)

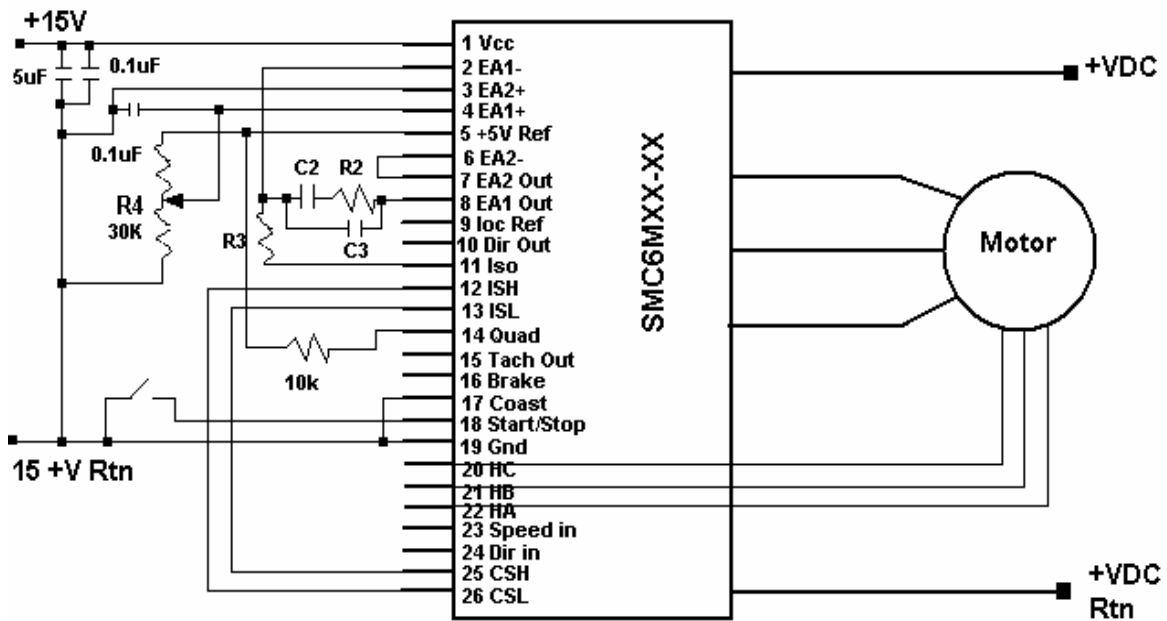

Fig. 10. Closed-Loop Current Control
(Four Quadrant Operation)

DC Bus Filtering

To minimize the circuit parasitic inductance effect on the power stage, the layout of Fig. 11 is suggested. C1, C2, and C3 are 0.1 μ F to 0.5 μ F ceramic capacitors, connected across each leg of the three-phase bridge. Also, a bulk polarized capacitor C4 of 10 μ F to 15 μ F per ampere of average motor current should be connected across the DC bus.

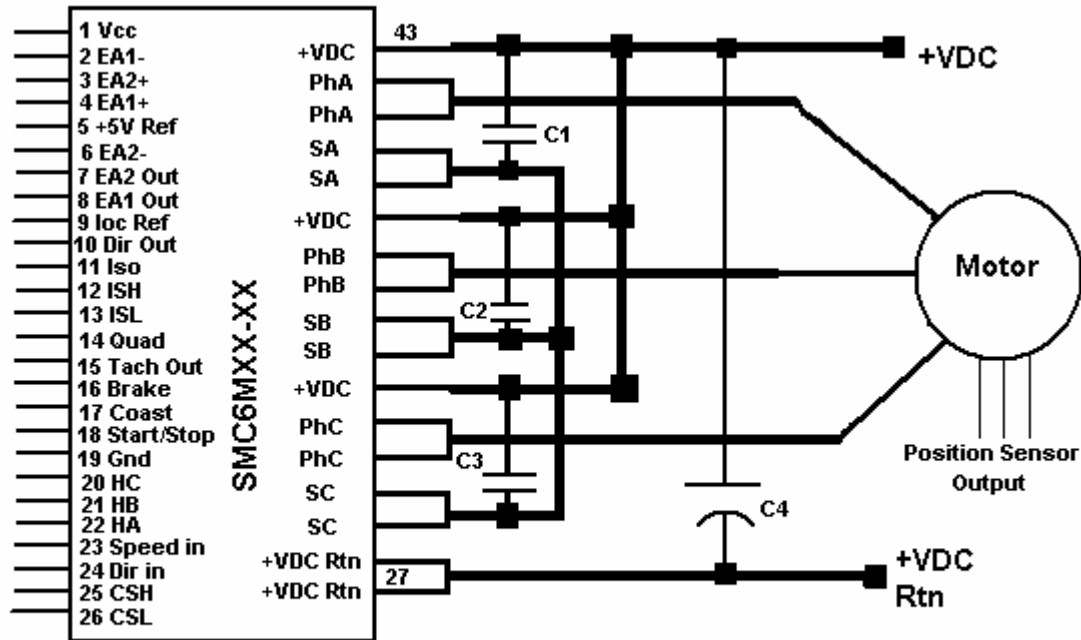

Fig. 11. DC Bus Bypass Capacitors

Cleaning Process:

Suggested precaution following cleaning procedure:

If the parts are to be cleaned in an aqueous based cleaning solution, it is recommended that the parts be baked immediately after cleaning. This is to remove any moisture that may have permeated into the device during the cleaning process. For aqueous based solutions, the recommended process is to bake for at least 2 hours at 125°C.

Do not use solvents based cleaners.

Recommended Soldering Procedure:

Signal pins 1-26: 210C for 10 seconds max

Power pins 27 to 43: 260C for 10 seconds max.

TECHNICAL DATA
DATA SHEET 1023, REV. E

DISCLAIMER:

- 1- *The information given herein, including the specifications and dimensions, is subject to change without prior notice to improve product characteristics. Before ordering, purchasers are advised to contact the Sensitron Semiconductor sales department for the latest version of the datasheet(s).*
- 2- *In cases where extremely high reliability is required (such as use in nuclear power control, aerospace and aviation, traffic equipment, medical equipment, and safety equipment), safety should be ensured by using semiconductor devices that feature assured safety or by means of users' fail-safe precautions or other arrangement.*
- 3- *In no event shall Sensitron Semiconductor be liable for any damages that may result from an accident or any other cause during operation of the user's units according to the datasheet(s). Sensitron Semiconductor assumes no responsibility for any intellectual property claims or any other problems that may result from applications of information, products or circuits described in the datasheets.*
- 4- *In no event shall Sensitron Semiconductor be liable for any failure in a semiconductor device or any secondary damage resulting from use at a value exceeding the absolute maximum rating.*
- 5- *No license is granted by the datasheet(s) under any patents or other rights of any third party or Sensitron Semiconductor.*
- 6- *The datasheet(s) may not be reproduced or duplicated, in any form, in whole or part, without the expressed written permission of Sensitron Semiconductor.*
- 7- *The products (technologies) described in the datasheet(s) are not to be provided to any party whose purpose in their application will hinder maintenance of international peace and safety nor are they to be applied to that purpose by their direct purchasers or any third party. When exporting these products (technologies), the necessary procedures are to be taken in accordance with related laws and regulations.*